

Safety switching device Output expansion SNE 4003K

Distributed by
General Safety Company Ltd.
(416) 645-0242

Output expansion with relay for base devices in safety applications

- Stop category 0 and 1 according to EN 60204-1 (see "Notes")
- Applications up to safety category 4 according to EN 954-1 (see "Notes")
- Safe isolation according to EN 50178
- Single-channel or two-channel control
- 3 enabling current paths (NO contact), 2 signaling current paths (NC contact)
- Broad input voltage range from DC 15 to 30 V
- Suitable for semiconductor control



Applications

- Expansion of a base device's enabling current paths
- Contact expansion in safety equipment system
- Output power increase for light curtains

Function

Device description

The SNE 4003K is an expansion device for base devices (such as safety switching devices, light curtains, laser scanners) that are part of the machine's safety equipment and are used for protecting people, material and machine.

The device is designed with two channels and redundancy. The enabling current paths are separated from the control circuits and signaling circuits with creepage distances and clearances > 5.5 mm (safe isolation). There is basic insulation to separate the enabling current paths from one another and the control circuits from the signaling current paths. The broad input voltage range of DC 15 V to DC 30 V makes the SNE 4003K ideal for single-channel or two-channel control by semiconductors.

Description of functions

Input voltage to the SNE 4003K is routed via one or two enabling current paths of a base device. When the input voltage is applied relays K1 and K2 switch into the ON position. After this switch-on phase, enabling current paths 13/14, 23/24, 33/34 are closed and feedback current path Y1/Y2 and signaling current path 41/42 are opened. This is displayed through two LEDs, K1 and K2, which are assigned to relays K1 and K2. If the enabling current paths of the base device are opened when the emergency stop button is operated, relays K1 and K2 on the SNE 4003K switch back into the OFF position. The enabling current paths open and the feedback current path closes. Feedback current path Y1/Y2 prevents the base device from switching on again before K1 or K2 releases.

Notes

Proper use

The SNE 4003K can be used as an expansion device for all base devices that are part of the machine's safety equipment and are used for protecting people, material and machinery. The feedback current path Y1/Y2 must be wired to the reset or feedback loop of the base device.

- The stop and safety categories achieved by the SNE 4003K always depend on the categories of the base device (the category of the expansion device cannot exceed that of the base device).
- The expansion relays K1 and K2 are controlled via one or two enabling current paths, depending on the required level of safety.
- The device and the contacts must be protected with max. 6 A utilization category gG or through circuit breakers with trigger characteristic B or C.
- The devices must be installed in a control cabinet with a protection degree of at least IP 54.

Please also note the information provided by your trade association.

Circuit diagram

SNE 4003K / K-A

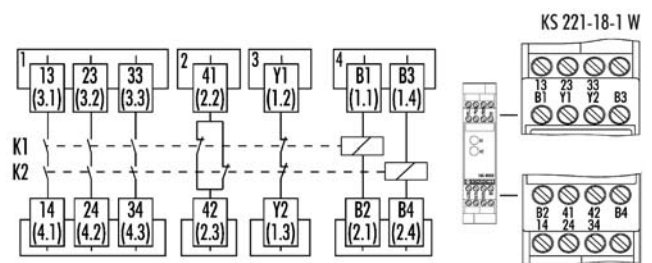

Designation of the SNE 4003K-A pluggable terminals in brackets

Function diagram

SNE 4003K

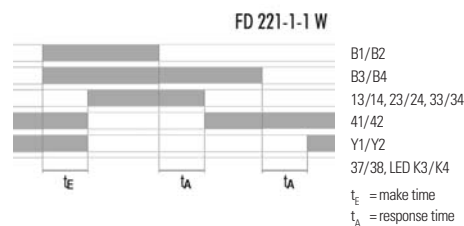

Safety switching device

Output expansion SNE 4003K

Application examples

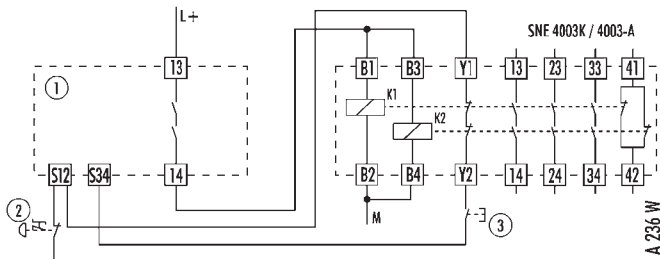

Single-channel control

- (1) Base device
- (2) Emergency stop button
- (3) Reset button

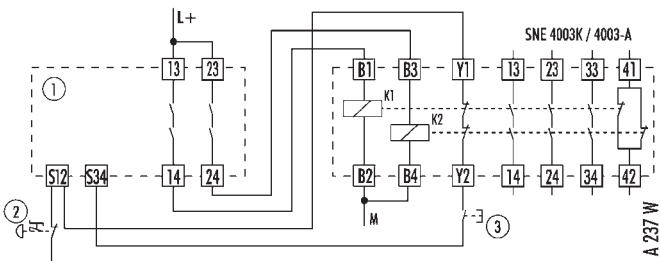

Two-channel control

- (1) Base device
- (2) Emergency stop button
- (3) Reset button

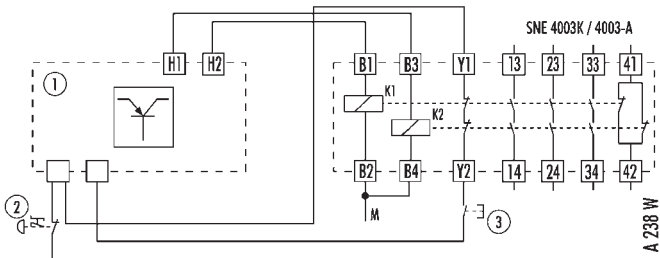

Semiconductor control

- (1) Base device
- (2) Emergency stop button
- (3) Reset button

Dimension diagram

SNE 4003K

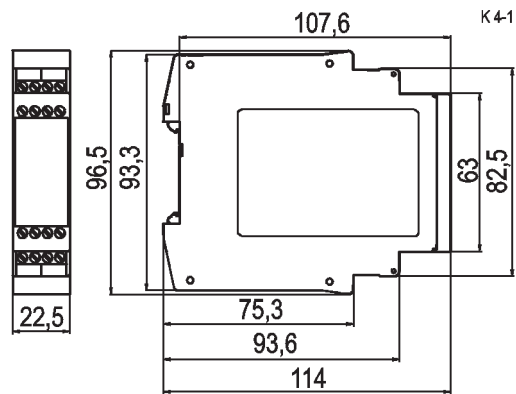

SNE 4003K-A

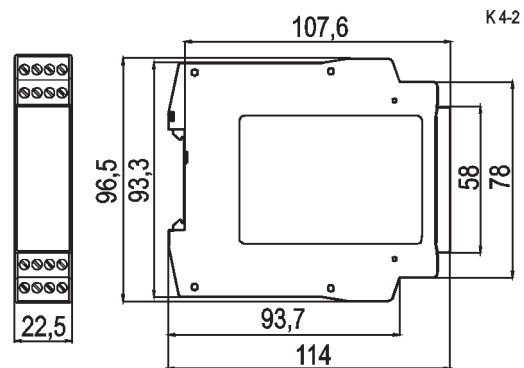

Safety switching device

Output expansion SNE 4003K



Technical data		SNE 4003K		
Function according to EN 60204-1		Emergency stop expansion relay		
Function display		2 LEDs green		
Function diagram		FD 221-1-1 W		
Control circuits B1/B2 and B3/B4				
Rated voltage		DC 24 V		
Input voltage range		DC 15 V – DC 30 V		
Rated consumption		1.2 W		
Rated current / max. peak current		50 mA/500 mA		
Make time t_E		K1, K2	< 40 ms	
Response time t_A		K1, K2	< 20 ms	
Recovery time t_W			≤ 40 ms	
Output circuits				
Contact assignment		3 enabling current paths (NO contact) 1 signaling path (NC contact, parallel) 1 feedback path (NC contact, serial) positively driven		
Contact type		positively driven		
Rated operating voltage U_n		AC 230 V/DC 300 V		
Max. continuous current I_n per enabling current path		6 A		
Max. total current of all enabling current paths		12 A		
Max. continuous current I_n per signaling current path		2 A		
Application category according to EN 60947-5-1		AC-15: U_e 230 V, I_e 3 A DC-13: U_e 24 V, I_e 2.5 A		
Short-circuit protection, max. fuse insert		6 A class gG or circuit breaker with trigger characteristic B or C		
Mechanical life		1 × 10 ⁶ switching cycles		
General data				
Creepage distances and clearances between the circuits		according to EN 60664-1		
Overvoltage category		IV		
Rated impulse voltage		6 kV		
Rated voltage		AC 300 V		
Test AC voltage		2 kV		
Degree of pollution		3 outside, 2 inside		
Protection degree according to DIN EN 60529 (housing / terminals)		IP 40/IP 20		
Ambient temperature		-25 – +55 °C		
Dimension diagram		K 4-1 (screw terminals / K 4-2 (pluggable terminals)		
Rated cross sections fine-stranded/solid or fine-stranded with ferrules		2 × 0.14 – 0.75 mm ² /1 × 0.14 – 2.5 mm ² 1 × 0.25 – 2.5 mm ² /2 × 0.25 – 0.5 mm ²		
Permissible tightening torque for UL and CSA applications		0.5 – 0.6 Nm		
		Wire ranges	AWG 18-16 only use Cu wires	
		Max. tightening torques	5.25 in-lbs	
Weight		0.21 kg		
Accessories		–		
Approvals				
Overview of the devices/Part numbers				
Type	Rated voltage	Terminals	Part No.	Std. Pack
SNE 4003K	DC 24 V	Terminal block, rising cage termination	R1.188.1330.0	1
SNE 4003K-A	DC 24 V	Pluggable connector, rising cage termination	R1.188.1340.0	1